

PowerXL™

DE11



Quick-Start-Guide	AP040092EN
Title	DE11 Quick-Start-Guide (from Firmware 2.00)
Product	PowerXL™ DE11
Level 2	<p>1 – Fundamental – No previous experience necessary</p> <p>2 – Basic – Basic knowledge of Variable Speed Starter recommended</p> <p>3 – Advanced – Basic knowledge of Variable Speed Starter required</p> <p>4 – Expert – Good experience recommended</p>



Powering Business Worldwide

Contents

Contents	2
Danger! - Dangerous electrical voltage!.....	3
Disclaimer	4
General	5
Environmental conditions	6
High availability	6
Overvoltage control.....	6
PWM regulation (Auto-Temperature-Management).....	7
DC-Braking.....	7
Status LEDs	7
Reset.....	8
Configuration module DXE-EXT-SET	8
Motor protection.....	10
Functions of the signals at the control terminals.....	11
Configuration of the control terminals	12
Full parameter access.....	15
Configuration of the analog input	16
Configuration of digital input 3 (terminal 3)	16
Configuration of relay output (Terminals 13 and 14)	16
DC braking	17
Start-Mode and Auto Reset.....	17
Modbus	18
CANOpen	18
SmartWire	18
Parameter list	19

Danger! - Dangerous electrical voltage!

- Disconnect the power supply of the device.
- Ensure that devices cannot be accidentally restarted.
- Verify isolation from the supply.
- Cover or enclose any adjacent live components.
- Follow the engineering instructions (AWA/IL) for the device concerned.
- Only suitably qualified personnel in accordance with EN 50110-1/-2 (VDE 0105 Part 100) may work on this device/system.
- Before installation and before touching the device ensure that you are free of electrostatic charge.
- The functional earth (FE, PES) must be connected to the protective earth (PE) or the potential equalization. The system installer is responsible for implementing this connection.
- Connecting cables and signal lines should be installed so that inductive or capacitive interference does not impair the automation functions.
- Suitable safety hardware and software measures should be implemented for the I/O interface so that an open circuit on the signal side does not result in undefined states.
- Deviations of the mains voltage from the rated value must not exceed the tolerance limits given in the specification, otherwise this may cause malfunction and dangerous operation.
- Emergency stop devices complying with IEC/EN 60204-1 must be effective in all operating modes. Unlatching the emergency-stop devices must not cause a restart.
- Devices that are designed for mounting in housings or control cabinets must only be operated and controlled after they have been properly installed and with the housing closed.
- Wherever faults may cause injury or material damage, external measures must be implemented to ensure a safe operating state in the event of a fault or malfunction (for example, by means of separate limit switches, mechanical interlocks etc.).
- Variable Speed Starters may have hot surfaces during and immediately after operation.
- Removal of the required covers, improper installation or incorrect operation of motor or Variable Speed Starter may destroy the device and may lead to serious injury or damage.
- The applicable national accident prevention and safety regulations apply to all work carried on live Variable Speed Starters.
- The electrical installation must be carried out in accordance with the relevant regulations (e. g. with regard to cable cross sections, fuses, PE).
- Transport, installation, commissioning and maintenance work must be carried out only by qualified personnel (IEC 60364, HD 384 and national occupational safety regulations).
- Installations containing Variable Speed Starters must be provided with additional monitoring and protective devices in accordance with the applicable safety regulations. Modifications to the Variable Speed Starters using the operating software are permitted.
- All covers and doors must be kept closed during operation.
- To reduce the hazards for people or equipment, the user must include in the machine design measures that restrict the consequences of a malfunction or failure of the Variable Speed Starter (increased motor speed or sudden standstill of motor). These measures include:
 - Other independent devices for monitoring safety related variables (speed, travel, end positions etc.).
 - Electrical or non-electrical system-wide measures (electrical or mechanical interlocks).
 - Never touch live parts or cable connections of the Variable Speed Starter after it has been disconnected from the power supply. Due to the charge in the capacitors, these parts may still be alive after disconnection. Consider appropriate warning signs.

Disclaimer

The information, recommendations, descriptions, and safety notations in this document are based on Eaton's experience and judgment and may not cover all contingencies. If further information is required, an Eaton sales office should be consulted. Sale of the product shown in this literature is subject to the terms and conditions outlined in the applicable Terms and Conditions for Sale of Eaton or other contractual agreement between Eaton and the purchaser. THERE ARE NO UNDERSTANDINGS, AGREEMENTS, WARRANTIES, EXPRESSED OR IMPLIED, INCLUDING WARRANTIES OF FITNESS FOR A PARTICULAR PURPOSE OR MERCHANTABILITY, OTHER THAN THOSE SPECIFICALLY SET OUT IN ANY EXISTING CONTRACT BETWEEN THE PARTIES. ANY SUCH CONTRACT STATES THE ENTIRE OBLIGATION OF EATON. THE CONTENTS OF THIS DOCUMENT SHALL NOT BECOME PART OF OR MODIFY ANY CONTRACT BETWEEN THE PARTIES. As far as applicable mandatory law allows so, in no event will Eaton be responsible to the purchaser or user in contract, in tort (including negligence), strict liability, or otherwise for any special, indirect, incidental, or consequential damage or loss whatsoever, including but not limited to damage or loss of use of equipment, plant or power system, cost of capital, loss of power, additional expenses in the use of existing power facilities, or claims against the purchaser or user by its customers resulting from the use of the information, recommendations, and descriptions contained herein. The information contained in this manual is subject to change without notice.

General

This Quick-Start-Guide gives a short introduction into the handling of the Variable Speed Starters DE11 (VSS). It is assumed that the measures described in the installation leaflet, which is supplied with the product, have been taken into account.

- Variable Speed Starter DE11 IL040005ZU
- Configuration module DXE-EXT-SET IL040020ZU

Please see manuals MN040011EN and MN040036EN for more detailed information.

Variable Speed Starters can be used for a plurality of applications as it comes out of the box. In default the following functions are available:

- DE11-12..... (0,25 ... 2,2 kW)
 - Mains supply 1~ 200 (-10 %) ... 240 V (+10 %)
 - Motor feeder 3~ 0 - 200 ... 240 V
- DE11-34..... (0,37 ... 7,5 kW)
 - Mains supply 3~ 380 V (-10 %) ... 480 V (+10 %)
 - Motor feeder 3~ 400 ... 480 V
- Protective functions
 - Motor feeder short circuit proof and ground fault proof
 - Motor protection set to rated current of the device
 - Protected against
 - Overvoltage
 - Undervoltage
 - Overtemperature
- Speed reference 0...10 V, corresponds to an output frequency of 0...50 Hz (60 Hz in USA and in Variant DE11...N01)
- 3 digital inputs (High-Signal 10 ... 24 V, either coming from DE11 itself or from an external source, e.g. PLC)
 - Forward (FWD)
 - Reverse (REV)
 - Fixed frequency 1 (FF1), set to 20 Hz
- Fault message via a potential-free contact (up to 230 V~) between terminals 13 and 14. Switching conditions:
 - ON
 - No fault AND
 - START command (FWD or REV) present
 - OFF
 - In case of fault: directly
 - After removal of the START command (FWD or REV). In case the motor ramps to stop (P-05 = 1 = Default) the contact opens at speed zero.
- Ramp times set to 5 s.

Environmental conditions



With the exception of DE11-34016..... all sizes of the Variable Speed Starter DE11 can be used in the temperature range between -10 °C and +60 °C without any derating.

Derating for DE11-34016.... see manual MN040011EN.

VSS can be mounted on a mounting plate or on a top hat rail (DIN rail).

Please note that the devices DE1-121D4..., DE1-122D3... and DE1-122D7... may have a max deviation of $\pm 5^\circ$ from the vertical. For all other DE11 devices a deviation of up to 90° (= horizontal mounting) is permitted.

Details for group protection and branch protection in UL environment are given inside the manual MN04011EN.

High availability



During the conception phase a high attention was given to a failure-free operation and the prevention of unintended trips. There are countermeasures to prevent tripping due to overvoltage caused by regenerative operation of the motor, tripping at high operating temperatures and tripping due to overcurrents from motors which are already spinning when the Variable Speed Starter is enabled.

If necessary, these functions can also be disabled. The Variable Speed Starter itself is still protected in this case but trips may occur.

In default the Variable Speed Starter trips once a fault is detected and has to be reset. It is also possible to activate the function "Auto-Restart", which resets the VSS automatically up to 9 times (number of Resets can be selected) and restarts the device. This function may only be activated when an automatic restart doesn't lead to a dangerous situation for people and goods.

Overvoltage control

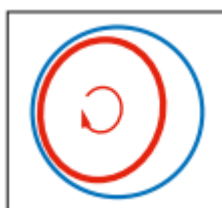

DE11 Variable Speed Starters have an internal algorithm, which prevents trips due to overvoltage in case of regenerative braking of the motor. Output voltage and frequency are adjusted in a way that there is no energy flowing back to the VSS device.

Application examples:

- Ramp down time set too short: the overvoltage control extends the ramp time automatically to avoid regeneration.
- The motor is driven by the load, e.g. washing machines and other applications with imbalance. To prevent overvoltage trips the Variable Speed Starter increases its output voltage and frequency automatically. The result is a small increase in speed which is acceptable in many applications.

This function can be disabled with P-31.

PWM regulation (Auto-Temperature-Management)



The temperature at the heatsink of the device depends on several factors, e.g. the environmental temperature and the cooling conditions. In addition the motor current and the switching frequency are important. In case a temperature close to the max. limit is detected, the Variable Speed Starter DE11 reduces the switching frequency automatically, which leads to a reduction of the DE11 losses. In many cases this prevents a trip because of overtemperature.

DC-Braking



When enabling the Variable Speed Starter, a motor, which is already spinning, can cause a high inrush current which is detected as a short circuit with the consequence of a trip. This depends on certain conditions like speed, time of enabling..... An application example is a fan which is mounted in a wind tunnel and which is driven by the natural air flow.

To prevent a trip DE11 offers the possibility to inject DC current into the motor before starting. This function results in a short time delay between start signal and start of the motor. This function is not activated in default. If DC braking is required, the function can be activated. See further down in this Quick-Start-Guide

Status LEDs

The LEDs on the front of the Variable Speed Starter indicate operating status and faults

- Run (green)
 - OFF = Fault or DE11 not supplied
 - Flash every 2 s = Ready, no start signal (FWD/REV)
 - ON = RUN
- Status (red)
 - OFF = DE11 OK
 - Flash every 0,5 s: Undervoltage e.g. during power up
 - ON = Fault
 - 3 flashes, followed by 2 s pause = Fire Mode is active
- Fault Code (Red)
 - 1 x Flash + 2 s OFF overload
 - 2 x Flash + 2 s OFF external fault
 - 3 x Flash + 2 s OFF over voltage
 - 4 x Flash + 2 s OFF over current (motor protection)
 - 5 x Flash + 2 s OFF over temperature at the heatsink
 - 6...13 x Flash internal fault
- Fault Code (yellow)
 - DC braking active

●	Run
●	Status
●	Fault Code
1 pulse	- overload
2 pulses	- external fault
3 pulses	- over voltage
4 pulses	- over current
5 pulses	- over temperature

Reset

After a fault message a reset is necessary to restart the Variable Speed Starter after elimination of the root cause.

Reset is possible

- By disconnecting the supply voltage at the terminals L1/N at DE11-12... respectively L1/L2/L3 at DE11-34... and reapplying it
- With a rising edge of the start signal (FWD / REV)
- automatically, where the DE11 is configured accordingly (see „Startmode and Auto Reset“)
- via Modbus or SWD, if used

Configuration module DXE-EXT-SET

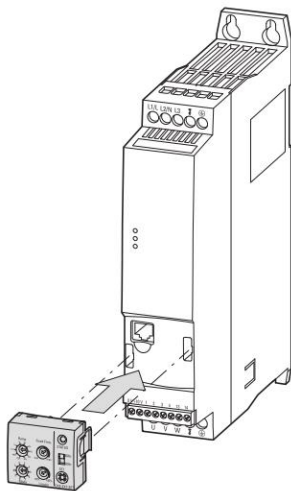

DXE-EXT-SET is an optional module, which can be plugged onto the front of the Variable Speed Starter. It is used for simple modification of selected parameters without using a PC or keypad. All sizes of DE11 use the same module.

It can be plugged and unplugged when live. The module is not necessary to operate DE11 after a parameter change. It can be removed after use. The settings are “stored mechanically” by the position of the switches and potentiometers.

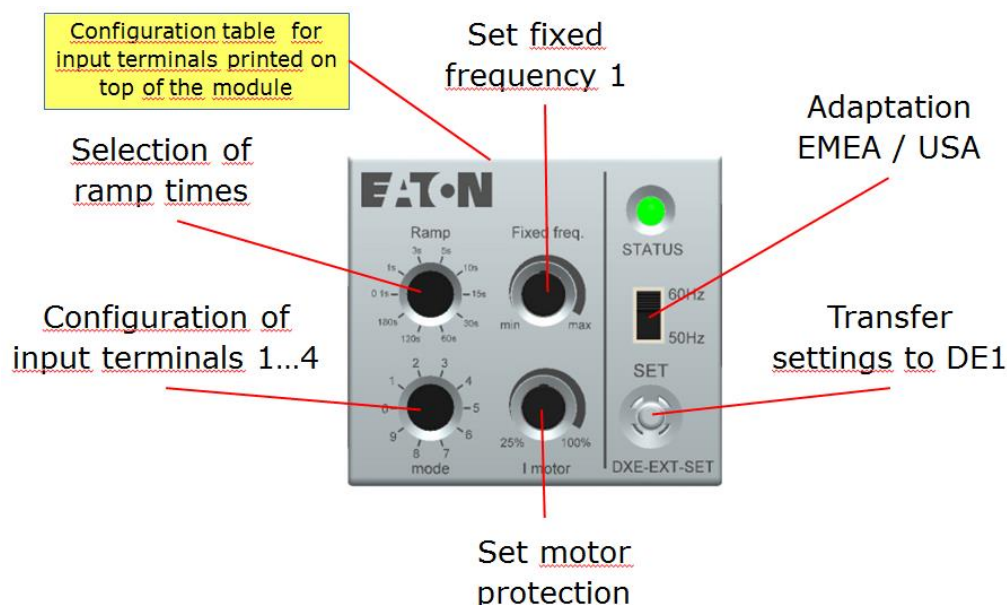

Designation	Settings	Function
Ramp	0,1 s / 1 s / 3 s / 5 s / 10 s / 15 s / 30 s / 60 s / 120 s / 180 s	Selection of ramp times. Values are equal for acceleration and deceleration ramp
Fixed freq	0 ... 100 % f-max	Setting of Fixed Frequency 1 with potentiometer (Default: 20 Hz). After pushing the SET button for a short time (< 2 s) the Fixed Frequency 1 can be adjusted while the motor is running. To deactivate the pot: push button again.
50 Hz / 60 Hz	50 Hz / 60 Hz	Adaptation of motor rated voltage, motor rated frequency and max. frequency to the supply network in Europe or North America
I motor	10 % ... 100 %	Setting of the motor protection 100 % = DE11 rated current
Mode	0...9	Configuration of input terminals 1...4 0 = FWD/REV/FF1/REF 1 = FWD/REV/EXTFLT/REF 2 = FWD/REV/FF2 ⁰ /FF2 ¹ 3 = FWD/FF1/EXTFLT/REF 4 = FWD/UP/FF1/DOWN 5 = FWD/UP/EXTFLT/DOWN 6 = FWD/REV/UP/DOWN 7 = FWD/FF2 ⁰ /EXTFLT/FF2 ¹ 8 = START/DIR/FF1/REF 9 = START/DIR/EXTFLT/REF
SET		Push for > 2 s to transfer settings to DE11. Push shortly for activation / deactivation of Fixed Frequency pot.
Status	LED	<ul style="list-style-type: none"> • Green: Settings of module are equal to DE11 • Yellow: Settings of module and DE11 are different • 3 flashes for 2 s each: settings are transferred successfully • Flashing with 4 Hz: Potentiometer for Fixed Frequency active

Motor protection



The internal motor protection protects the motor against overload. In default the motor protection is set to the device's rated current. It can be set to values between 10 and 100 % of the rated current by using the potentiometer "I motor" on the configuration module. If a keypad or the PC software DrivesConnect is used, the motor protection is set with P-08.

An overload is detected by the Variable Speed Starter and when the protection setting is exceeded the DE11 trips with an over current message. In default the Variable Speed Starter is configured in a way, that the thermal memory is activated and the content will be stored even when the unit is switched off. This means that the value is still present when restarting the VSS and the memory is not reset. If a reset of the thermal memory is required by the application it can be configured by P-33.

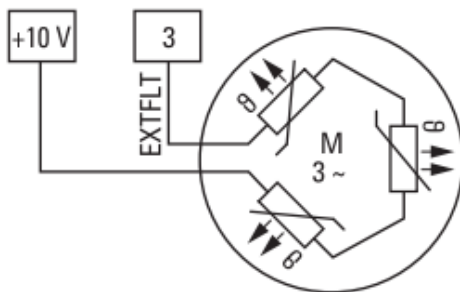

Depending on the configuration of the input terminals the function „external fault“ (EXTFLT) is assigned to terminal 3. This Input can also be used to connect a thermistor. Wiring see picture on the left hand side.

A fault is detected when the resistance is greater than 3600 Ohm. A reset of the fault is possible when the resistance is below 1600 Ohm and the motor has cooled down.

Application hint: DE11 is built according IEC/EN 61800-5-1 where it is required to have a reinforced insulation between mains circuits and low voltage circuits. For that reason, a reinforced insulation between the thermistors and the motor windings is required not to weaken the overall insulation system of the PDS (Power Drive System).

Functions of the signals at the control terminals

- FWD / REV
 - Selection of the direction of rotation with High signal
 - Both signals at the same time = motor coasts to stand still (XOR)
- FF1
 - H = Selection of fixed frequency 1
 - The speed changes from the analog reference (REF) to fixed frequency 1
- REF
 - Analog input for reference 0...10 V
- EXTFLT
 - P-45 = 0
 - External fault. DE1 trips if signal is missing
 - Connection of digital signal or thermistor possible
 - P-45 = 1...4
 - Fire Mode input. The behavior of the drive depends on the setting of P-45. See parameter list.
- FF2⁰ / FF2¹
 - Selection of fixed frequencies 1...4 with digital signals

	FF2 ⁰	FF2 ¹
f-Fix1	L	L
f-Fix2	H	L
f-Fix3	L	H
f-Fix4	H	H

- UP / DOWN
 - Increases / decreases speed with digital signal
- START / DIR
 - START = START command
 - Direction of rotation selected with DIR. L = Forward, H = Reverse
 - ATTENTION: in this configuration a wire break at H-Signal (REV) leads to a reversion of the direction of rotation of the motor.



Configuration of the control terminals

In default Variable Speed Starters are configured for terminal mode (P-12 = 0). The following information refers to this mode only. Settings of P-12 different from zero may lead to other terminal configurations (see manual MN040011EN).

There are 10 different terminal configurations which can be selected either with the selection switch Mode on the configuration module or with parameter P-15.

<p>Mode 0</p> <p>Default</p> <ul style="list-style-type: none"> • 2 directions (FWD / REV) • Speed reference via potentiometer (0 ... 10 V) • Fixed frequency FF1, default = 20 Hz. With High-Signal at terminal 3 the reference changes from the analog value at terminal 4 to fixed frequency 1 (P-21) 																										
<p>Mode 1</p> <p>External fault</p> <ul style="list-style-type: none"> • 2 directions (FWD / REV) • Speed reference via potentiometer (0...10 V) • Terminal 3 is used as External Fault input. To operate VSS a High Signal is necessary (Fail safe). If the signal at terminal 3 is missing DE11 trips and an external fault is indicated. It is also possible to connect a thermistor to terminal 3. Details see "motor protection". 																										
<p>Mode 2</p> <p>Fixed frequencies (1)</p> <ul style="list-style-type: none"> • 2 directions (FWD/REV) • Selection of fixed frequencies via binary coded inputs (FF2⁰ / FF2¹) <table border="1" data-bbox="335 1541 694 1774"> <thead> <tr> <th>Fixed frequency</th> <th>FF2⁰</th> <th>FF2¹</th> <th>f₂</th> <th>PNU</th> </tr> </thead> <tbody> <tr> <td>FF1</td> <td>L</td> <td>L</td> <td>20 Hz</td> <td>P-20</td> </tr> <tr> <td>FF2</td> <td>H</td> <td>L</td> <td>30 Hz</td> <td>P-21</td> </tr> <tr> <td>FF3</td> <td>L</td> <td>H</td> <td>40 Hz</td> <td>P-22</td> </tr> <tr> <td>FF4</td> <td>H</td> <td>H</td> <td>50 Hz</td> <td>P-23</td> </tr> </tbody> </table>	Fixed frequency	FF2 ⁰	FF2 ¹	f ₂	PNU	FF1	L	L	20 Hz	P-20	FF2	H	L	30 Hz	P-21	FF3	L	H	40 Hz	P-22	FF4	H	H	50 Hz	P-23	
Fixed frequency	FF2 ⁰	FF2 ¹	f ₂	PNU																						
FF1	L	L	20 Hz	P-20																						
FF2	H	L	30 Hz	P-21																						
FF3	L	H	40 Hz	P-22																						
FF4	H	H	50 Hz	P-23																						

<p>Mode 3</p> <p>One direction</p> <ul style="list-style-type: none"> • 1 direction (FWD) • Speed reference via potentiometer (0 ... 10 V) • Fixed frequency FF1. Details see Mode 0 • External fault (EXTFLT). Details see Mode 1 																										
<p>Mode 4</p> <p>Digital reference (1)</p> <ul style="list-style-type: none"> • 1 direction (FWD) • Speed reference via fixed frequency 1 or the inputs for the digital reference (UP / DOWN). • With UP the reference will be increased, with DOWN reduced. In case UP and DOWN are applied at the same time, DOWN gets priority. 																										
<p>Mode 5</p> <p>Digital reference (2)</p> <ul style="list-style-type: none"> • 1 direction (FWD) • Speed reference via inputs for the digital reference (UP / DOWN). • With UP the reference will be increased, with DOWN reduced. In case UP and DOWN are applied at the same time, DOWN gets priority. • External fault (EXTFLT). Details see Mode 1 																										
<p>Mode 6</p> <p>Digital reference (3)</p> <ul style="list-style-type: none"> • 2 directions (FWD / REV) • Speed reference via inputs for the digital reference (UP / DOWN). • With UP the reference will be increased, with DOWN reduced. In case UP and DOWN are applied at the same time, DOWN gets priority. 																										
<p>Mode 7</p> <p>Fixed frequencies (2)</p> <ul style="list-style-type: none"> • 1 direction (FWD) • External fault (EXTFLT). Details see Mode 1 • Selection of fixed frequencies via binary coded inputs (FF2⁰ / FF2¹) <table border="1" data-bbox="331 1780 694 2011"> <thead> <tr> <th>Fixed frequency</th> <th>FF2⁰</th> <th>FF2¹</th> <th>f₂</th> <th>PNU</th> </tr> </thead> <tbody> <tr> <td>FF1</td> <td>L</td> <td>L</td> <td>20 Hz</td> <td>P-20</td> </tr> <tr> <td>FF2</td> <td>H</td> <td>L</td> <td>30 Hz</td> <td>P-21</td> </tr> <tr> <td>FF3</td> <td>L</td> <td>H</td> <td>40 Hz</td> <td>P-22</td> </tr> <tr> <td>FF4</td> <td>H</td> <td>H</td> <td>50 Hz</td> <td>P-23</td> </tr> </tbody> </table>	Fixed frequency	FF2 ⁰	FF2 ¹	f ₂	PNU	FF1	L	L	20 Hz	P-20	FF2	H	L	30 Hz	P-21	FF3	L	H	40 Hz	P-22	FF4	H	H	50 Hz	P-23	
Fixed frequency	FF2 ⁰	FF2 ¹	f ₂	PNU																						
FF1	L	L	20 Hz	P-20																						
FF2	H	L	30 Hz	P-21																						
FF3	L	H	40 Hz	P-22																						
FF4	H	H	50 Hz	P-23																						

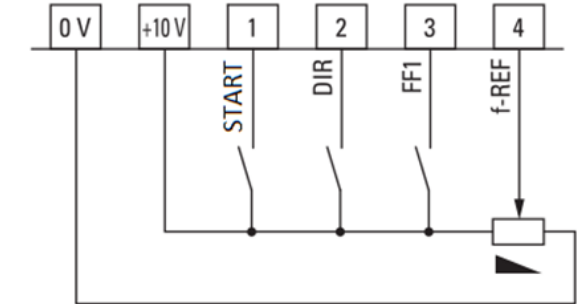
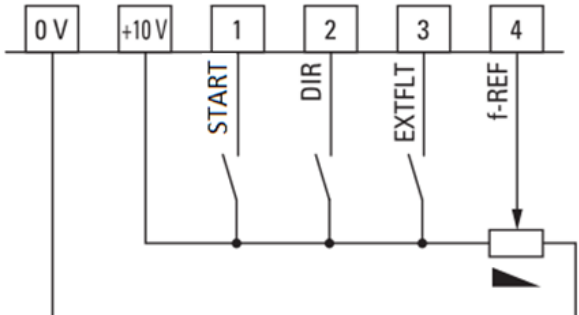
<p>Mode 8</p> <p>Machine control (1)</p> <ul style="list-style-type: none"> • 2 directions, selected with DIR. (L = FWD, H = REV) • Speed reference via potentiometer (0 ... 10 V) • Fixed frequency FF1. Details see Mode 0 • Enabling of the Variable Speed Starter with START <p>Hint: In case of wire break at terminal 2 (DIR = REV) the motor will reverse automatically!</p>	
<p>Mode 9</p> <p>Machine control (2)</p> <ul style="list-style-type: none"> • 2 directions, selected with DIR. (L = FWD, H = REV) • Speed reference via potentiometer (0 ... 10 V) • External fault (EXTFLT). Details see Mode 1 • Enabling of the Variable Speed Starter with START <p>Hint: In case of wire break at terminal 2 (DIR = REV) the motor will reverse automatically!</p>	

Full parameter access

In case access to additional parameters is needed, this can be achieved by using:

- the optional keypad DX-KEY-LED (V1.2 and above)
- the parameter software DrivesConnect. Free Download:

<http://www.drive-support-studio.com/OTS/Eaton/downloads/deploy/drivesConnect.htm>

- the communication system SmartWire DT in connection with the option module DX-NET-SWD3
- Modbus RTU

The Variable Speed Starter can be accessed via the RJ45 socket on front of the device. For handling details please refer to the respective manuals and the DE11 manual MN040011EN.

Handling with DX-KEY-LED...

- Press **OK** for 2 s to access parameter level
- The parameter used previously will be displayed.
- Select parameter with ▲ and ▼
- Press **OK** . Change values with ▲ and ▼
- Press **OK** to acknowledge
- Press **OK** for 2 s to leave parameter level.

Access to the extended parameter set (Level 2)

The parameters of the Variable Speed Starter DE11 are divided into two levels.

- The standard parameter set, containing the 14 most common parameters (P-01 ... P-14)
- The extended parameter set (Level 2)

The extended parameter set can be accessed by entering a code in P-14. In default the code is 101. This code can be modified by the user by changing parameter P-38.

- P-14 equal to P-38 → access to the extended parameter set
- P-14 different to P-38 → quit extended parameter set

Configuration of the analog input

In case an analog input is needed (P-15 = 0 / 1 / 3 / 8 / 9), this functionality is assigned to terminal 4.

A configuration of the analog input can be done as follows:

- Voltage- or current input signal (P-16 = AI1 Signal Range)
 - 0 ... 10 V
 - 0 ... 20 mA
 - 4 ... 20 mA, trips if signal is below 3 mA (wire break)
 - 4 ... 20 mA, ramps to fixed frequency 1 if signal is below 3 mA (wire break)
- Scaling (P-17 = AI1 Gain)

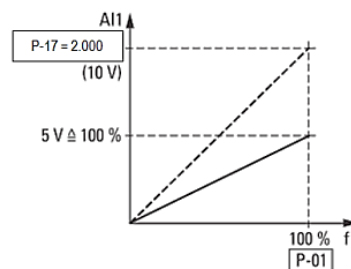

- Inversion (P-18 = AI1 Invert)
 - P-18 = 0 0 V = min frequency 10 V = max frequency
 - P-18 = 1 0 V = max frequency 10 V = min frequency
- Offset (P-44)

Configuration of digital input 3 (terminal 3)

In case terminal 3 is configured to be used for an external fault signal (EXTFLT, P-15 = 1 / 3 / 5 / 7 / 9), it can be used as „normal“ digital input or for the connection of a thermistor (see also: chapter “motor protection”). A special configuration is not necessary.

The logic can be inverted with P-19 (DI3 Logic)

- 0 → High = OK, Low = Fault (necessary for thermistor)
- 1 → Low = OK, High = Fault

In case P-45 is set to 1...4, the digital input is used for fire mode. In this case P-19 (DI3 Logic) is not effective.

- High = Normal operation
- Low = Fire mode

Configuration of relay output (Terminals 13 and 14)

Four parameters have an impact on the functionality of the relay contact.

P-51	RO1 Function	selection between 10 possible functions
P-52	RO1 Upper Limit	determines the switching threshold of the relay (P-51 = 4 / 5 / 6 / 7)
P-53	RO1 Hysteresis	
P-54	RO1 Switch-On Delay	

More detailed information see parameter list

DC braking

Parameter P-25 defines the operation of the DC braking. In default DC braking is disabled. DC-Braking before Start can be activated, to bring spinning motors to stand still before the Variable Speed Starter starts. This is to prevent trips because of too high inrush currents (Fans).

The duration of the braking is set with P-26 (t-DCBrake@Stop). This time applies for a braking before start as well as for one after a stop command.

The DC voltage during the braking period is set with P-27 (DCBrake Voltage) as a percentage of the motor's rated voltage (P-07). Higher values = higher braking torque

P-28 (f-DCBrake@Stop) defines the threshold at which DC braking after stop will be activated. The value is given as output frequency in Hz. Before reaching the threshold the motor decelerates with the ramp set with P-04. The Stop Mode (P-05) has to be set to "Ramping".

In cases where Stop Mode is set to "Coasting" DC braking starts immediately after a stop command. P-28 (f-DCBrake@Stop) is ineffective.

During DC braking the LED "Fault code" appears yellow

Start-Mode and Auto Reset

The behavior of the Variable Speed Starter DE11 at start is selected with parameter P-30 (Default: Auto-0)

- EdgE-r → Following power on or reset DE11 will not start if a start signal (FWD/REV) is still present. To start, a rising edge at FWD/REV is necessary.
- Auto-0 → Following a power on or reset DE11 will automatically start if a start signal (FWD/REV) is still present.
- Auto-1 ... Auto-9 → Following a trip, DE11 will make up to 9 attempts to restart automatically at 20 seconds intervals. The number of restart attempts is counted and if DE11 doesn't restart, it trips after the final attempt. In this case reset has to be done manually. The counter of attempts can only be reset by removing the power from the DE11 device.

Modbus

Variable Speed Starters DE11 can be connected to a Modbus network. In this case the following parameter settings are necessary:

- P-12 = 3 (ProcessDataAccess)
- P-35 (RS485-0 Baudrate) → Setting of the baudrate
- P-36 (Modbus RTU0 COM Timeout) → Behavior at communication loss
- P-47 (RS485-0 Address) to be set to the DE1's address in the Modbus network

Terminal 1 is used as hardware enable and requires a High signal to operate DE11 via Modbus. For additional changes of the terminal configuration compared to the settings in default see manual MN040011EN.

CANOpen

Variable Speed Starters DE11 can be connected to a CANOpen network. In this case the following parameter settings are necessary:

- P-12 = 4 (ProcessDataAccess)
- P-34 (PDP-Address) to be set to the DE11's address in the CANOpen network
- P-50 (CAN0 Baudrate) → Setting of the baudrate
- P-36 (Modbus RTU0 COM Timeout) → Behavior at communication loss

Terminal 1 is used as hardware enable and requires a High signal to operate DE11 via Modbus. For additional changes of the terminal configuration compared to the settings in default see manual MN040011EN.

SmartWire

When using the option module DX-NET-SWD3 Variable Speed Starters DE11 can communicate with the SmartWire system. In this case the following parameter settings are necessary:

- P-12 = 9 (ProcessDataAccess)

Terminal 1 is used as hardware enable and requires a High signal to operate DE11 via SmartWire. For additional changes of the terminal configuration compared to the settings in default and for additional operating modes see manual MN040011EN.

Parameter list

PNU	SWD Address	Access RUN		Designation	Range	Default	Description
P-01	20.1	-	r/w	f-max	$f_{\min} \dots 300.0$ Hz	50/60 Hz	Sets the upper limit for the speed of the motor. This can be set to any value between "f-min" and 5x the "motor nom frequency". "Motor Nom Speed" (P-10) = 0, the maximum speed limit will be displayed in Hz. "Motor Nom Speed" (P-10) > 0, the maximum speed limit will be displayed in rpm.
P-02	20.0	-	r/w	f-min	$0 \dots f_{\max}$	0 Hz	Sets the lower limit for the speed of the motor. This can be set to any value between 0 and "f-max" (P-01) "Motor Nom Speed" (P-10) = 0, the minimum speed limit will be displayed in Hz. "Motor Nom Speed" (P-10) > 0, the minimum speed limit will be displayed in rpm.
P-03	111.0	Y	r/w	t-acc	0 ... 300 s	5.0 s	Sets the acceleration ramp time in seconds. The time interval set in "t-acc" represents the time taken to accelerate from zero to "Motor Nom Frequency" (P-09).
P-04	114.0	Y	r/w	t-dec	0 ... 300 s	5.0 s	Sets the deceleration ramp time in seconds. The time interval set in "t-dec" represents the time taken to decelerate from "Motor Nom Frequency" (P-09) to zero.
P-05	620.1	Y	r/w	Stop Mode	0/1	1	Determines the action taken by the Variable Speed Starter in the event of the start signal (FWD/REV) being removed. 0 = Coasting. When the start signal is removed, DE11 output is immediately disabled, and the motor will coast (freewheel) to stop. 1 = Ramping. When the start signal is removed, DE11 will ramp to stop, with the rate controlled by "t-dec" (P-04).
P-06	626.1	-	r/w	Energy Optimizer	0/1	0	When energy optimization is activated, the motor voltage is dynamically varied, dependent on load. This results in reduced voltage being applied to the motor on light load, significantly reduce energy consumption. This mode of operation is less suitable for dynamic applications where the load conditions can suddenly increase significantly. 0 = Energy Optimizer deactivated 1 = Energy Optimizer activated
P-07*	211.0	-	r/w	Motor Nom Voltage	50...500 V	220 V / 230 V / 380 V / 400 V / 460 V	Defines the Motor rated voltage, i.e. the voltage applied to the motor when operating at "Motor Nom Frequency". When the output frequency is greater than the "Motor Nom Frequency" (P-09), the output voltage is controlled at the level set with "Motor Nom Voltage" (P-07).
P-08*	210.0	-	r/w	Motor Nom Current	$0.1 I_e \dots I_e$	I_e	By setting the "Motor Nom Current" in the VSS, the motor overload protection is configured to match the motor rating. When the measured motor current exceeds "Motor Nom Current", the decimal points on the optional display will flash to indicate an overload condition. If this condition persists, the VSS will eventually trip, displaying I.t-trP, preventing thermal overload of the motor.
P-09	216.0	-	r/w	Motor Nom Frequency	20.0... 300 Hz	50/60 Hz	The rated frequency of the motor. This is the frequency at which "Motor Nom Voltage" is applied to the motor. Below this frequency, the applied motor voltage will be reduced. Above this frequency the voltage remains limited to "Motor Nom Voltage" (P-07)
P-10	217.0	-	r/w	Motor Nom Speed	0/ 200...18000 rpm	0 rpm	The motor rated speed is set using this parameter. If "Motor Nom Speed" = 0, the speed of the motor will be displayed in Hz. If "Motor Nom Speed" > 0, the speed related parameters (f-max, f-min etc.) will be displayed in rpm. The slip compensation is also activated, where the shaft speed of the motor is maintained under varying load conditions by compensating for the load-dependent slip of the motor. If "Motor Nom Speed" = motor synchronous speed (e.g. 3000rpm for a 2-pole 50Hz motor), the speed can be displayed in rpm without activating the slip compensation.

PNU	SWD Address	Access RUN		Designation	Range	Default	Description
		Y	r/w				
P-11	27.0	Y	r/w	V-Boost	0.0 ... 40.0 %	3.0 % (3.5 % at DE1-129D6)	Used to increase the applied motor voltage at low output frequency, in order to improve low speed and starting torque. Excessive voltage boost levels may result in increased motor current and temperature, and forced ventilation may be required.
P-12	928.0	Y	r/w	ProcessDataAccess	0...13	0	Defines who has control for commands and reference values. 0 = Terminal Control. The VSS responds directly to signals applied to the control terminals. 1 = Uni-directional Keypad Control. The VSS can be controlled in the forward direction only using an external or remote Keypad 2 = Bi-directional Keypad Control. The VSS can be controlled in the forward and reverse directions using an external or remote Keypad. Pressing the keypad START button toggles between forward and reverse. 3 = Modbus Control. Control via Modbus RTU communication. 4 = CANopen control (internal ramp times) 5 = CANopen control (ramp times via CANopen) 9 = SmartWire Device Control and speed ref. 10 = SmartWire Device Control and terminal speed ref. 11 = Terminal Control and SmartWire Device speed ref. 12 = not allowed 13 = SmartWire Device Control and speed ref. Digital input sets enable.
P-13*	947.0 ... 947.7	-	r	Last Fault (Last Fault.....Last Fault7)	...	-	Displays the last 8 fault codes for the VSS. <ul style="list-style-type: none"> - I²t motor - External fault - Over temperature - Over voltage - Over Current - Earth fault - Communication Fault SWD
P-14	320.0	Y	r/w	Password	0...65535	0	Entry of the password to get access to the extended parameter set. The value to be put in is determined by P-38 (default = 101). Extended parameters are accessible.
P-15	423.0	-	r/w	DI Config Select	0...9	0	Configuration of digital inputs. The setting of P-15 determines the input configuration depending on P-12. Configuration with P-12 = 0 (Terminal mode): 0 =FWD/REV/FF1/REF 1 =FWD/REV/EXTFLT/REF 2 =FWD/REV/FF2 ⁰ /FF2 ¹ 3 =FWD/FF1/EXTFLT/REF 4 =FWD/UP/FF1/DOWN 5 =FWD/UP/EXTFLT/DOWN 6 =FWD/REV/UP/DOWN 7 =FWD/FF2 ⁰ /EXTFLT/FF2 ¹ 8 =START/DIR/FF1/REF 9 =START/DIR/EXTFLT/REF Refer to the manual for further information.
P-16	260.0	-	r/w	AI1 Signal Range	0...3	0	Configures the Analog input 1 for the selected signal source type. 0-10V 0-20mA t 4-20mA (Trip in case of wire break) r 4-20mA (Ramps to f-fix1 (P-20) in case of wire break)
P-17	261.0	Y	r/w	AI1 Gain	0.100 ...2.500	1.000	Scaling of the Analog Input 1 Output value = Input value * Scaling. Example: P-16 = 0...10 V, P-17 = 2,000: at 5 V the motor turns with max speed (P-01) (5 V * 2 = 10 V)
P-18	267.0	-	r/w	AI1 Invert	0/1	0	Setting this parameter to 1 inverts the logic of the analog input. 0: 0 V / 0(4) mA = min frequency, 10 V / 20 mA = max frequency 1: 0 V / 0(4) mA = max frequency, 10 V / 20 mA = min frequency
P-19	650.2	-	r/w	DI3 Logic	0/1	0	This parameter defines the logic of the digital input 3. 0: High = ok, Low = Fault 1: Low = ok, High = Fault (when P15 is set to 1,3,5, 7 or 9 (External Fault))
P-20	5.1	-	r/w	f-Fix1	f _{min} ... f _{max}	20 Hz	Preset Fixed Frequency 1 Value can be adjusted between f-min (P-02) and f-max (P-01).

PNU	SWD Address	Access RUN		Designation	Range	Default	Description
							Selection via a digital control signal.
P-21	5.2	-	r/w	f-Fix2	$f_{min} \dots f_{max}$	30 Hz	Preset Fixed Frequency 2 Value can be adjusted between f-min (P-02) and f-max (P-01). Selection via a digital control signal.
P-22	5.3	-	r/w	f-Fix3	$f_{min} \dots f_{max}$	40 Hz	Preset Fixed Frequency 3 Value can be adjusted between f-min (P-02) and f-max (P-01). Selection via a digital control signal.
P-23	5.4	-	r/w	f-Fix4	$f_{min} \dots f_{max}$	50 Hz	Preset Fixed Frequency 4 Value can be adjusted between f-min (P-02) and f-max (P-01). Selection via a digital control signal.
P-24	620.3	Y	r/w	Digital Reference Reset Mode	0...3	0	Defines the behaviour of DE11 on START when used in Keypad control or when controlled with UP/DOWN commands via terminals. 0 = Start at min speed 1 = Start with latest speed before switching off 2 = Start at min speed (Auto-r) 3 = Start with latest speed before switching off (Auto-r) Auto r: START and STOP button on the keypad are disabled. DE11 starts with a START command at the terminals.
P-25	2221.0	-	r/w	DCBrake	0 ... 3	0	Sets the instances when DC braking is enabled. 0 = OFF 1 = On at Stop 2 = On before Start 3 = On before Start and at Stop
P-26	2222.1	Y	r/w	t-DCBrake@Stop	0.0 ... 10s	0.0 s	Duration of DC braking at Stop and before Start
P-27	2220.0	Y	r/w	DCBrake Voltage	0.0 ... 100%	0.0 %	Amount of DC voltage as a percentage of the "Motor Nom Voltage" (P-07) that is applied to the motor during DC braking.
P-28	2223.0	Y	r/w	f-DCBrake@Stop	0.0 ... P-01	0.0 %	Output frequency at which DC braking starts during the deceleration phase. If "Stop Mode" is set to coasting, DC braking starts at stop command immediately.
P-29*	390.0	-	r/w	Switching Frequency	4 ... 32 kHz 10 ... 20 kHz	16 kHz	Power stage switching frequency. Higher frequency reduces the audible 'ringing' noise from the motor, and improves the output current waveform, at the expense of increased heat losses within DE11. 1~: 4/8/12/16/24/32 kHz 3~: 10/12/14/16/18/20kHz
P-30	620.0	-	r/w	Start Mode	0...10	Auto-0	Defines the behaviour of the VSS relating to the enable digital input and also configures the automatic restart function. Edge-r = Following power on or reset, the VSS will not start if a start signal (FWD/REV) is still present. To start DE11 a rising edge is necessary. Auto-0 = Following a power on or reset, the VSS will automatically start if digital input 1 is closed. Auto-1 to 9 = Following a trip, the VSS will make up to 9 attempts to restart at 20 second intervals. The VSS must be powered down to reset the counter. The number of restart attempts is counted, and if the VSS fails to start on the final attempt, the VSS will trip, and will require the user to manually reset the fault.
P-31	626.3	Y	r/w	Overvoltage Control	0/1	0	The overvoltage control prevents the VSS from tripping in case of regenerative energy feedback from the motor to the DC link. When disabled, the VSS will trip "Over Voltage" instead of automatically increasing the motor ramp times when the VSS is decelerating the motor too quickly. 0 = Overvoltage Controller enabled 1 = Overvoltage Controller disabled
P-32	624.0	-	r/w	Auto Thermal Management	0/1	0	When disabled, the VSS will trip "Over Temperature" instead of automatically reducing the power stage switching frequency when the VSS gets hot. 0 = Thermal management enabled 1 = Thermal management disabled
P-33	682.0	-	r/w	Switch Remanant Storage	0/1	0	When enabled, the motor thermal memory retention function will save the calculated motor thermal history on VSS power down, using this saved value as the starting value on next power up. If this function is disabled, the motor thermal history is reset to zero on every power up. 0 = Thermal memory enabled 1 = Thermal memory disabled

PNU	SWD Address	Access RUN		Designation	Range	Default	Description
P-34	918.0	Y	r/w	PDP-Address	1...63	1	Unique VSS address for communication network.
P-35	3222.0	Y	r/w	RS485-0 Baudrate	0...4	4	Modbus Baudrate 0 = 960 Bit/s 1 = 19.2 kBit/s 2 = 38.4 kBit/s 3 = 57.6 kBit/s 4 = 115.2 kBit/s
P-36	362.0	Y	r/w	Modbus RTU0 COM Timeout	0...8	0	Modbus RTU0 COM Timeout Time between a communication loss and the resulting action. Setting "0" disables the action after communications trip. t: indicates the VSS will trip if time exceeded. r: indicates the VSS will ramp to stop if time exceeded. 0 = no action 1 = t 30 ms 2 = t 100 ms 3 = t 1000 ms 4 = t 3000 ms 5 = r 30 ms 6 = r 100 ms 7 = r 1000 ms 8 = r 3000 ms
P-37	976.0	-	r/w	Parameter Set	0/1	0	Restores factory parameter settings. 1 = Restore (This is reset to 0 by the VSS).
P-38	320.1	Y	w	Password Level2	0...9999	101	Defines the password which is used to get access to extended parameter set (Level 2). Access via P-14.
P-39	625.0	Y	r/w	Parameter Lock	0/1	0	Determines whether to lock the parameters 0 = Unlocked. All parameters can be accessed and changed 1 = Locked. Parameter values can be displayed, but cannot be changed. If a remote keypad is connected, parameters cannot be accessed by the remote keypad if they are locked.
P-40	840.29952	Y	r/w	Action@Communication Loss	0 ... 4	0	VSS reaction after SWD master communication loss. Master communication loss delay time is set by P-36 0 = No reaction, continue work 1 = Set warning, continue work 2 = stop (if ramp enabled) 3 = coast stop 4 = Trip
P-41	927.0	Y	r/w	Parameter Access	0/1	0	Parameter Access 0 = All parameters can be changed by any source. 1 = All parameters locked; can only be changed by the SWD device.
P-42	22.0	Y	rw	f-SkipBand1	0.0 – P-01	0	Band width of the skip frequency Defines the frequency range around f-Skip1, where the drive is not operated stationary to avoid mechanical resonances inside the application. During acceleration and deceleration this range is passed through by using the ramps set with P-03 and P-04.
P-43	210.0	Y	rw	f-Skip1	0,0 – P-01	0	Defines the center point of the frequency band defined with f-SkipBand1, where the drive is not operated stationary.
P-44	262.0	Y	rw	AI1Offset	-1.000 - +1.000	0	Offset Analog Input 1
P-45	640.0	Y	rw	FireMode Function	0 – 4	0	Defines the functionality of the drive in applications, where fire mode is used. The fire mode signal is applied to terminal 3 (DI3). Only settings of P-15 are permitted, in which the function EXTFLT is assigned to terminal 3 (P-15 = 1, 3, 5, 7, 9). P-45 determines the behavior of the device in fire mode. Running in fire mode is indicated by the LED "Status" (3 x flash + 2 s pause). During fire mode, the signals at terminals 1 (DI1) and 2 (DI2) are not effective. 0: Fire Mode disabled 1: Fire Mode 1 - At removing the signal at terminal 3, fire mode is activated and the motor turns clockwise (FWD). - The speed reference during fire mode is the analog reference at terminal 4 (AI1). - When this reference fails or in case it is zero at the time of activating fire mode, the motor runs with fixed frequency 4 (f-Fix4 = P-23). This remains, even when the analog value comes back. 2: Fire Mode 2 - At removing the signal at terminal 3, fire mode is activated and the

PNU	SWD Address	Access RUN		Designation	Range	Default	Description
							motor turns counter clockwise (REV). - The speed reference during fire mode is the analog reference at terminal 4 (A1). - When this reference fails or in case it is zero at the time of activating fire mode, the motor runs with fixed frequency 4 (f-Fix4 = P-23). This remains, even when the analog value comes back. 3: Fire Mode 3 - At removing the signal at terminal 3, fire mode is activated and the motor turns clockwise (FWD). - The speed reference during fire mode is fixed frequency 4 (f-Fix4 = P-23). 4: Fire Mode 4 - At removing the signal at terminal 3, fire mode is activated and the motor turns counter clockwise (REV). - The speed reference during fire mode is fixed frequency 4 (f-Fix4 = P-23).
P-46	218.0	Y	rw	Motor Stator Resistance R1	0,00 – 655,35 Ω	f (le)	Stator resistance of the motor
P-47	3221.0	Y	rw	RS485-0 Address	1 – 255	1	Modbus Address When the SmartWire-DT module DX-NET-SWD3 is used, the address must be set to 1.
P-48	3224.0	Y	rw	RS485-0 ParityType	0-3	0	RS485 Parity 0: 1 start bit, 8 data bits, 1 stop bit, no parity 1: 1 start bit, 8 data bits, 2 stop bits, no parity 2: 1 start bit, 8 data bits, 1 stop bit, odd parity 3: 1 start bit, 8 data bits, 1 stop bit, even parity
P-50	3302.0	-	r/w	CAN0 Baudrate	0 ... 3	2	Sets the Baudrate in case CANopen is used 0: 125 kBit/s 1: 250 kBit/s 2: 500 kBit/s 3: 1000 kBit/s 4: 50 kBit/s 5: 20 kBit/s
P-51	451.0	Y	r/w	RO1 Function	0 ... 9	0	Selection of the function of output relay RO1 0: RUN, enable (FWD/REV) 1: READY, DE11 ready for operation 2: Speed = frequency reference value 3: Fault (DE11 not ready) 4: Speed >= RO1 Upper Limit (P-52) 5: Motor current >= RO1 Upper Limit (P-52) 6: Speed < RO1 Upper Limit (P-52) 7: Motor current < RO1 Upper Limit (P-52) 8: Drive not enabled 9: Motor not at target speed
P-52	452.0	Y	r/w	RO1 Upper Limit	0.0...200.0 %	100.0 %	Switching ON threshold of relay RO1 with P-51 = 4 ... 7)
P-53	454.0	Y	r/w	RO1 Hysteresis	0.0...100.0 %	0.0 %	This parameter defines a lower reaction threshold level in case P-51 is set to 4...7. Threshold level = limit (P-52) - hysteresis (P-53) P-51 = 4 or 5: output will be logic 1 if the value ≥ limit, output will be logic 0 if value < level P-51 = 6 or 7: output will be logic 0 if the value ≥ limit, output will be logic 1 if value < level
P-54	457.0	Y	r/w	RO1 Switch-On Delay	0.0...250.0 s	0.0 s	Delay time before the relay switches from logic 0 to logic 1

Display Values							
P00-01	560.0	Y	r	Analog Input1	0.0% ...100%	-	Level of the signal applied to analog input 1 after scaling and offsets have been applied.
P00-03	1.0	Y	r	Frequency Reference	0.0... 300 Hz	-	Value of the VSS internal digital reference (used for keypad)
P00-04	550.0 – 550.n	Y	r	DI1 Status	0000b- 1111b	-	Status of the digital inputs starting on the left hand side with digital input 1 etc.
P00-05	504.0	Y	r	Motor Current	0 ... 150 % I _e	-	Instantaneous output current
P00-06	502.0	Y	r	Output Frequency	0.0 ... 300.0 Hz	-	Instantaneous output frequency
P00-07	501.0	Y	r	Motor Voltage	0...480 V RMS	-	Instantaneous output voltage
P00-08	501.1	Y	r	DC-Link Voltage	V	-	Instantaneous DC Link Voltage
P00-09	822.0	Y	r	Heatsink Temperature	°C	-	Instantaneous Heatsink Temperature
P00-10	821.0	Y	r	t-Run			Total operating time of the VSS since the date of manufacture in hours, minutes and seconds. Pressing the UP key on the VSS keypad will change the display from "hours" to "minutes and seconds".
P00-11		Y	r	RunSincePowerOn			Total operating time of the VSS since the last trip occurred or the last power ON in hours, minutes and seconds. Pressing the UP key on the VSS keypad will change the display from "hours" to "minutes and seconds"
P00-12	821.5	Y	r	RunSinceLastTrip			Total operating time of the VSS since the last trip occurred in hours, minutes and seconds. Pressing the UP key on the VSS keypad will change the display from "hours" to "minutes and seconds"
P00-13	821.3	Y	r	t-HoursRunEnable			Total operating time of the VSS since the last VSS ENABLE signal was applied. Pressing the UP key on the VSS keypad will change the display from "hours" to "minutes and seconds"
P00-14	390.1	Y	r	Actual Switching Frequency			Switching frequency set with P-29 is displayed. The value may be less than the one set with P-29 when the thermal management of the heatsink is active.
P00-15	852.0 (...7)	Y	r	DC-Link0 Log (...Link7 Log)			DC Link voltage log, recording the most recent 8 samples of the DC bus voltage prior to a VSS trip condition occurring. The sample interval is 256ms.
P00-16	851.0 (...7)	Y	r	Heatsink0 Log (...sink7 Log)			Heatsink temperature log, recording the most recent 8 samples of the Heatsink temperature prior to a VSS trip condition occurring. The sample interval is 30s.
P00-17	855.0 (...7)	Y	r	MotorCurrent0 Log (...Current7 Log)			Motor current log, recording the most recent 8 samples of the Motor current prior to a VSS trip condition occurring. The sample interval is 256ms.
P00-18	206.0 & 206.1	Y	r	Application Version		-	Displays the software version and checksum of the VSS
P00-19	209.0	Y	r	Serial Number		-	Displays the unique serial number of the VSS.
P00-20	250.0 250.1 250.2 251.0 252.0 202.0	Y	r	DriveInformation		-	Type details of the VSS
P00-21	841.58370	Y	r	FaultCounter Fire detected			Indicates, how many times a fire was detected.
P00-22	821.11	Y	r	t-FireMode active			Total operating time of the VSS in fire mode in hours, minutes and seconds. Pressing the UP key on the VSS keypad will change the display from "hours" to "minutes and seconds".

(*) Parameter numbers marked with an asterisk are not transferred in cases where the source and destinations ratings do not match.