

PowerXL™

DC1 Variable Frequency Drives Operating Single Phase Motors

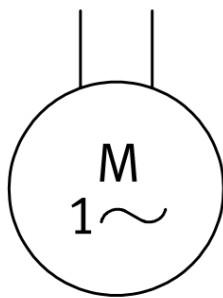

Level 2	<ul style="list-style-type: none"> 1 – Fundamental – No previous experience necessary 2 – Basic – Basic knowledge recommended 3 – Advanced – Reasonable knowledge required 4 – Expert – Good experience recommended
---------	---

Content

1	General	5
2	About the motor.....	6
2.1	Which type of motors may be used?	6
2.2	Selection of the variable frequency drive	6
2.3	Selecting the sense of rotation.....	6
2.4	Wiring	7
3	Starting of single phase motors.....	8
3.1	V-Boost (P-11), f-Boost (P-32), t-Boost (P-33).....	8
3.2	Commissioning	9
3.2.1	V-Boost (P-11).....	9
3.2.2	t-Boost (P-33)	9
3.2.3	f-Boost (P-32).....	10

Danger! - Dangerous electrical voltage!

- Disconnect the power supply of the device.
- Ensure that devices cannot be accidentally restarted.
- Verify isolation from the supply.
- Cover or enclose any adjacent live components.
- Follow the engineering instructions (AWA/IL) for the device concerned.
- Only suitably qualified personnel in accordance with EN 50110-1/-2 (VDE 0105 Part 100) may work on this device/system.
- Before installation and before touching the device ensure that you are free of electrostatic charge.
- The functional earth (FE, PES) must be connected to the protective earth (PE) or the potential equalization. The system installer is responsible for implementing this connection.
- Connecting cables and signal lines should be installed so that inductive or capacitive interference does not impair the automatic control functions.
- Suitable safety hardware and software measures should be implemented for the I/O interface so that an open circuit on the signal side does not result in undefined states.
- Deviations of the mains voltage from the rated value must not exceed the tolerance limits given in the specification, otherwise this may cause malfunction and/or dangerous operation.
- Emergency stop devices complying with IEC/EN 60204-1 must be effective in all operating modes. Unlatching of the emergency-stop devices must not cause a restart.
- Devices that are designed for mounting in housings or control cabinets must only be operated and controlled after they have been properly installed and with the housing closed.
- Wherever faults may cause injury or material damage, external measures must be implemented to ensure a safe operating state in the event of a fault or malfunction (e.g. by means of separate limit switches, mechanical interlocks etc.).
- Frequency inverters may have hot surfaces during and immediately after operation.
- Removal of the required covers, improper installation or incorrect operation of motor or frequency inverter may destroy the device and may lead to serious injury or damage.
- The applicable national safety regulations and accident prevention recommendations must be applied to all work carried on live frequency inverters.
- The electrical installation must be carried out in accordance with the relevant electrical regulations (e. g. with regard to cable cross sections, fuses, PE).
- Transport, installation, commissioning and maintenance work must be carried out only by qualified personnel (IEC 60364, HD 384 and national occupational safety regulations).
- Installations containing frequency inverters must be provided with additional monitoring and protective devices in accordance with the applicable safety regulations. Modifications to the frequency inverters using the operating software are permitted.
- All covers and doors must be kept closed during operation.
- To reduce the hazards for people or equipment, the user must include in the machine design measures that restrict the consequences of a malfunction or failure of the frequency inverter (increased motor speed or sudden standstill of motor). These measures include:
 - Other independent devices for monitoring safety related variables (speed, travel, end positions etc.).
 - Electrical or non-electrical system-wide measures (electrical or mechanical interlocks).
 - Never touch live parts or cable connections of the frequency inverter after it has been disconnected from the power supply. Due to the charge in the capacitors, these parts may still be alive after disconnection. Consider appropriate warning signs.

Disclaimer

The information, recommendations, descriptions, and safety notations in this document are based on Eaton's experience and judgment and may not cover all contingencies. If further information is required, an Eaton sales office should be consulted. Sale of the product shown in this literature is subject to the terms and conditions outlined in the applicable Terms and Conditions for Sale of Eaton or other contractual agreement between Eaton and the purchaser. THERE ARE NO UNDERSTANDINGS, AGREEMENTS, WARRANTIES, EXPRESSED OR IMPLIED, INCLUDING WARRANTIES OF FITNESS FOR A PARTICULAR PURPOSE OR MERCHANTABILITY, OTHER THAN THOSE SPECIFICALLY SET OUT IN ANY EXISTING CONTRACT BETWEEN THE PARTIES. ANY SUCH CONTRACT STATES THE ENTIRE OBLIGATION OF EATON. THE CONTENTS OF THIS DOCUMENT SHALL NOT BECOME PART OF OR MODIFY ANY CONTRACT BETWEEN THE PARTIES. As far as applicable mandatory law allows so, in no event will Eaton be responsible to the purchaser or user in contract, in tort (including negligence), strict liability, or otherwise for any special, indirect, incidental, or consequential damage or loss whatsoever, including but not limited to damage or loss of use of equipment, plant or power system, cost of capital, loss of power, additional expenses in the use of existing power facilities, or claims against the purchaser or user by its customers resulting from the use of the information, recommendations, and descriptions contained herein. The information contained in this manual is subject to change without notice.

1 General

The variable frequency drives DC1-S... of the **PowerXL™ DC1** series are intended to supply single phase motors. They have a single phase supply as well as a single phase motor connection. They are available in the power range between 0.37 and 1.5 kW.

To the greatest possible extend the functionality is equal to the one for three phase induction motors. Because of the special motor characteristic, especially during start, differences between devices for single phase motors and those for three phase motors are necessary.

This application note describes the specialties of the devices DC1-S... and their application.

Some required parameters are inside Level 2 of the menu. This level has to be activated by prompting the „Password Level2“ (P-37) into P-14 (Password). Password Level2 is „101“ by default.

2 About the motor

2.1 Which type of motors may be used?

The following types of motors can be supplied by devices DC1-S...:

- Single phase permanent split capacitor motors (PSC)
- Shaded pole type motors
- Three phase motors with Steinmetz wiring (with capacitor)

It has to be noted that the low speed performance of single phase motors is reduced, hence in general, it is not advised to reduce the speed below 50 % of the rated motor speed, unless the load reduces at lower speeds

Hint:

Some single phase motors have two capacitors fitted:

- one for starting, which is switched off by a centrifugal switch after start
- one for operation

When you want to control this kind of motor with a variable frequency drive, please contact the motor manufacturer for advice, because in some cases the capacitors can be destroyed. Therefore, Eaton does not recommend, to control such motors with a variable frequency drive.

2.2 Selection of the variable frequency drive

The single phase motors on the market vary a lot in terms of performance and efficiency. Therefore it is not possible to assign a certain motor power to a variable frequency drive. The selection has to be done based on the motor current.

Single phase motors have inherently lower starting torque compared to three phase motors, and in some cases it may be necessary to oversize the drive compared to the motor to ensure sufficient starting torque is generated.

2.3 Selecting the sense of rotation

It is not possible to change the sense of rotation of a single phase motor with a respective control signal at the terminals of the variable frequency drive. In cases where the terminal configuration selected with P-15 is normally used for both senses of rotation (P-15 = 0, 5, 6, 7, 8, 9, 11) the terminal for the second sense of rotation doesn't work.

The wiring of the motor determines the sense of rotation:

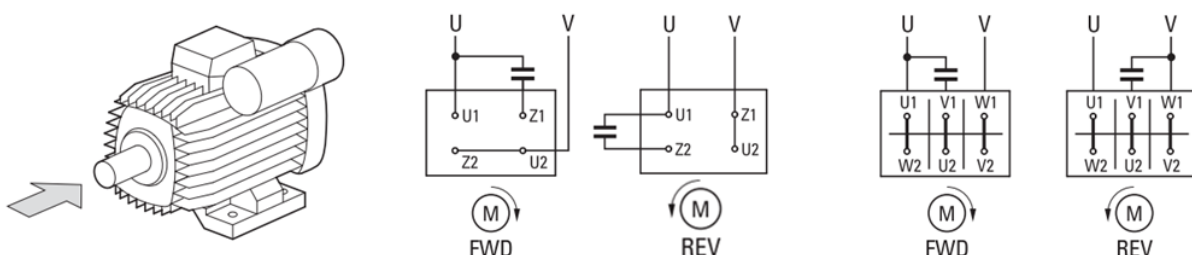

2.4 Wiring

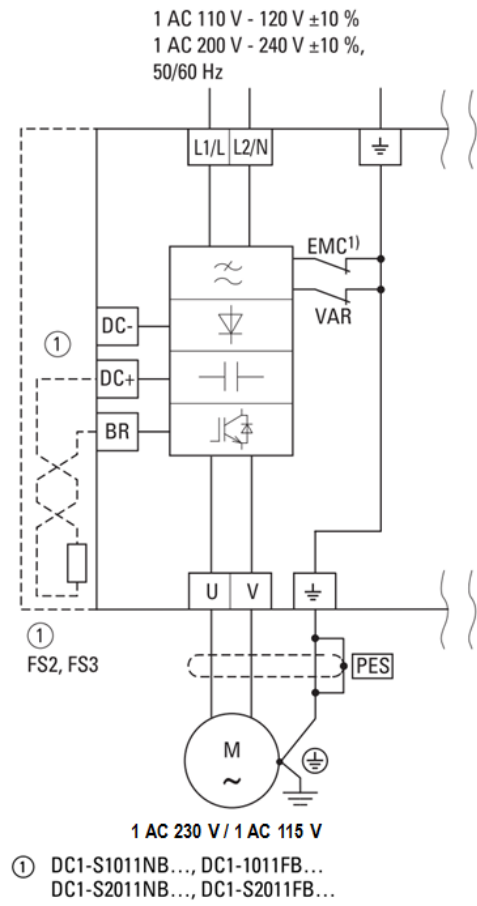

3 Starting of single phase motors

The speed control of single phase motors works like the one for three phase motors: by varying voltage and frequency. Solely the motor behavior at start is different. While a three phase motor follows its V/f curve right from the start signal, it is necessary to have a starting boost when using single phase motors. After the start the control of the motor speed works like the one for a three phase motor by following the V/f curve.

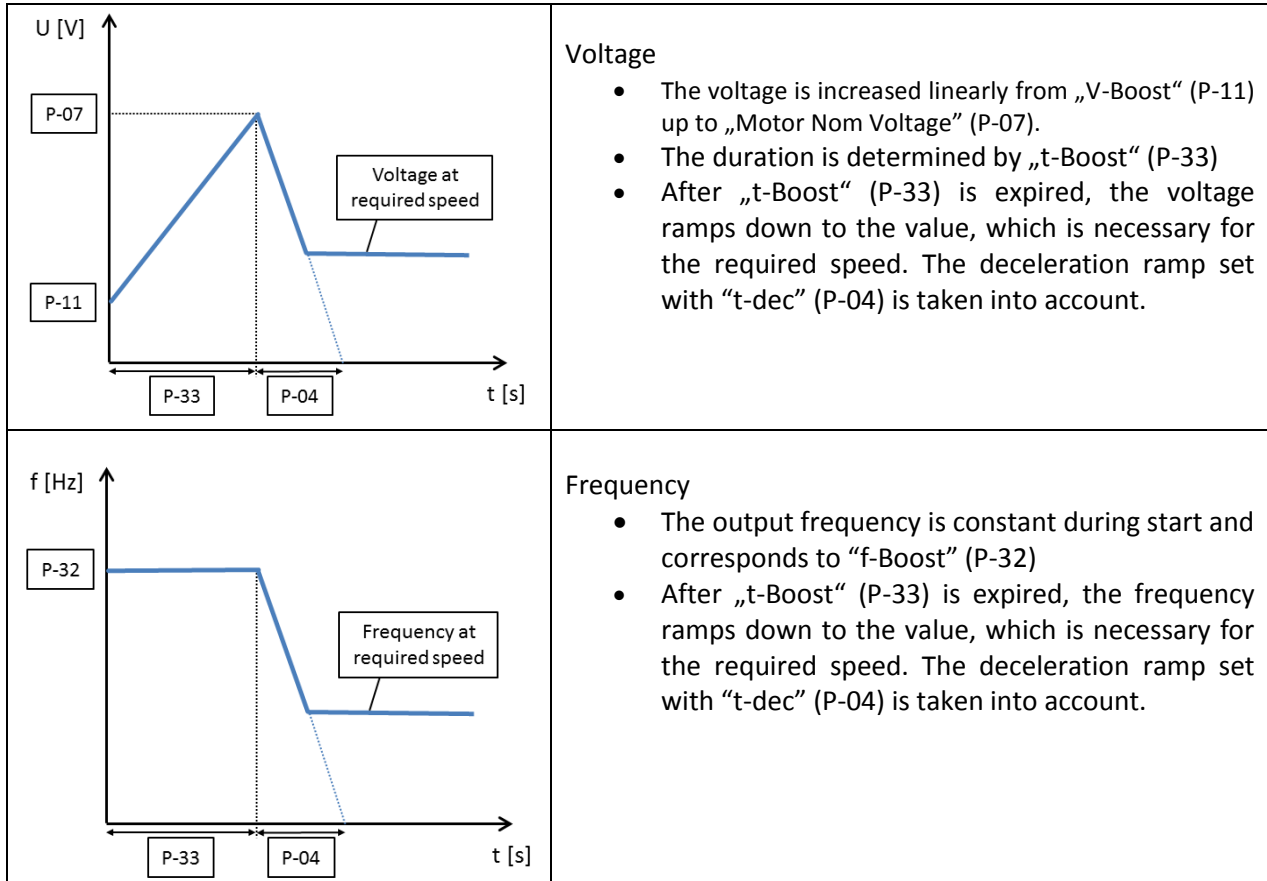

3.1 V-Boost (P-11), f-Boost (P-32), t-Boost (P-33)

V-Boost (P-11)

Voltage is used to increase the applied motor voltage at low output frequency, in order to improve low speed and starting torque. Excessive voltage boost levels may result in increased motor current and temperature, and forced ventilation may be required.

In devices intended for single phase motors (DC1-S...) P-11 also determines the voltage when starting.

f-Boost (P-32)

Frequency used to start a single phase motor. The setting "0" disables the boost function.

t-Boost (P-33)

Time, in which the motor is supplied with the frequency defined in P-32. The voltage increases linearly from P-11 to P-07. The setting "0" disables the boost function.

PNU	Parameter	Name	Range	Default
27.0	P-11	V-Boost	0 ... 100 % U _e	3 %
28.0	P-32	f-Boost	0 .. 120 Hz	50 Hz
29.0	P-33	t-Boost	0.0 150.0 s	5.0 s

3.2 Commissioning

It is assumed, that the variable frequency drive has its default settings when starting the commissioning.

- Make sure, that the motor is connected properly and that the starting load is in place to evaluate the right settings. Do not disconnect the load from the motor. Take care, that no danger can be generated by operating the motor.
- Enable access to parameter level 2 by entering the password into P-14 (Default: 101)
- Set parameters „Motor Nom Voltage“ (P-07) and „Motor Nom Current“ (P-08) to the values according to the motor nameplate.

3.2.1 V-Boost (P-11)

- Set parameter „t-Boost“ (P-33) to the maximum possible value (150.0 s). This allows the slowest possible ramp up of motor voltage, hence allowing the start voltage to be adjusted and the performance checked easily.
- Start the variable frequency drive and read the current on the drive display. Press the **OK** button until the display shows („R...xxx“).
- The current should rise quickly, then stabilize after a few seconds, rising very slowly from this point onwards. The value which should be noted is the stabilized current reading 3...5 seconds after start
 - If the current is **less** than **80 %** of the motor rated current:
 - Stop the variable frequency drive
 - Increase P-11
 - Repeat the test
 - If the current is **greater** than **90 %** of the motor rated current:
 - Stop the variable frequency drive
 - Reduce P-11
 - Repeat the test
 - The aim is to achieve a voltage setting whereby the motor draws 80 ... 90 % of the rated continuous current shortly after starting the variable frequency drive. This is the correct boost voltage for the motor.
- Note that the motor may not turn during this test. This is not important. It is only a procedure to determine the correct value for “V-Boost” (P-11).

3.2.2 t-Boost (P-33)

Once the correct boost voltage “V-Boost” has been determined, the boost period duration “t-Boost” (P-33) should be adjusted. Initially this can be done in large steps of as much as 50 % until it is close to the required value.

The correct boost period duration will be slightly longer (e.g. 1 ... 2 s) than required to start the motor to full speed. This can be determined by using the following procedure:

- Ensure the correct value for “V-Boost” (P-11) has been set according to the procedure described in 3.2.1.
- Ensure that the frequency reference is below the motor rated frequency. This ensures that, when the boost period ends, the motor will slow to this speed, hence it is easy to observe when the boost duration period “t-Boost” has elapsed.
- Start the variable frequency drive and read the current on the drive display. Press the **OK** button until the display shows („**R**...**xxx**“).
- Check that the motor starts to rotate as the voltage increases. As the motor starts to turn, the output current will increase, however once the motor reaches full speed, the current should reduce very quickly. If “t-Boost” is too long, however, the applied motor voltage will still be low at this point, so the motor will rotate with high current.
 - Approximately measure the time required from starting the variable frequency drive until the motor reaches full speed.
 - Reduce “t-Boost” (P-33) and repeat the test.
 - If the motor reaches full speed before the end of “t-Boost”, reduce “t-Boost” again and repeat the test.
 - **O-I** and **LETP** faults are common during the testing phase. If the device trips, allow at least 30 seconds before restarting.
 - If “t-Boost” is too long, this can result in the motor running with reduced voltage, and hence high current for a period after starting. In this case reduce “t-Boost” (P-33)

3.2.3 f-Boost (P-32)

In most cases „f-Boost“ (P-32) is equal to „Motor Nom Frequency“ and doesn't need to be changed during commissioning. If necessary the value can be modified.